



北京首钢股份有限公司
BEIJING SHOUGANG CO., LTD.

无取向电工钢 产品手册

NON-ORIENTED ELECTRICAL STEEL

北京首钢股份有限公司
Beijing Shougang Co., Ltd



Chapter 1 Shougang Group

第一章 首钢集团

北京首钢股份有限公司（简称“首钢股份”）是首钢集团所属的境内唯一上市公司。首钢股份于 1999 年 10 月由首钢总公司独家发起募集设立，1999 年 12 月在深圳证券交易所上市（证券代码：000959）。

首钢股份拥有迁钢公司、首钢智新迁安电磁材料有限公司，控股首钢京唐钢铁联合有限责任公司、北京首钢冷轧薄板有限公司等钢铁实体单位，具有焦化、炼铁、炼钢、轧钢、热处理等完整的生产工艺流程，产能 2147 万吨。首钢股份拥有国际一流装备和工艺水平，具有品种齐全、规格配套的冷热系全覆盖板材产品序列，为客户提供电工钢、汽车板、镀锡板、管线钢、家电板等优质产品和先期介入等增值服务。首钢股份致力于从产品制造商向综合服务商转变，努力成为具有世界竞争力的优秀上市公司。

Beijing Shougang Co.,Ltd. (hereinafter referred to as Shougang Co.,Ltd.) is the only domestic listed company of Shougang Group. Shougang Co.,Ltd. is a joint stock limited company established by means of raising in October 1999, listed in Shenzhen Stock Exchange since December 1999.(stock code 000959)

Shougang Co.,Ltd. owns Shougang Qian'an Iron and Steel Co.,Ltd. , Shougang Zhixin Qian' an Electromagnetic Materials Co.,Ltd., holding Shougang Jingtang United Iron & Steel Co.,Ltd., Beijing Shougang Cold Rolling Co.,Ltd., and other steel entities. Shougang Co.,Ltd. has the whole production processes including coking, iron making, steelmaking, rolling and annealing. The annual production capacity reaches 21.47 million tons. Shougang Co.,Ltd. stays as world-class level in the manufacture equipments and processes, achieved full coverage of hot-rolled and cold-rolled products, provided EVI services and high quality products such as electrical steel, automotive steel, tinplate, pipeline steel, appliance sheet. Shougang Co.,Ltd. is committed to transform from a product manufacturer to a comprehensive service provider, strive to become an excellent listed company with world competitiveness.

首钢智新迁安电磁材料有限公司

Shougang Zhixin Qian'an Electromagnetic Material Co., Ltd.

首钢智新迁安电磁材料有限公司（简称智新公司）是首钢股份公司于 2018 年 3 月 22 日在河北省迁安市设立的全资子公司，具备年产 150 万吨电工钢的生产能力，累计六年实现单体工厂产量全球第一。自主研发掌握了低铁损高纯净度控制工艺，高磁感组织系统控制，带钢断面轮廓控制成套工艺控制及低温板坯加热工艺等电工钢生产技术，电工钢产品广泛应用于高端家电、大电机、无人机、新能源汽车驱动电机、高效配电变压器及超特高压输电变压器等领域。产品性能和尺寸精度达到国内领先水平、家电行业无取向电工钢市场占有率全球第一、取向电工钢跻身变压器材料世界第一阵营，正在成长为“全球领先的电工钢制造商”。

Shougang Zhixin Qian'an Electromagnetic Material Co., LTD. (hereinafter referred to as Zhixin Company) is a wholly-owned subsidiary of Shougang Corporation established in Qian'an city, Hebei Province on March 22, 2018. It has an annual production capacity of 1.5 million tons of electrical steel, and has achieved the world's largest single plant output in six years. Independent research and development have low iron loss of high purity control technology, high magnetic induction texture system control, strip steel section contour control sets of process control and low temperature slab reheating technics, electrical steel production technologies such as electrical steel products are widely used in high-end home appliance, unmanned aerial vehicles, new energy vehicles, large motor drive motor, efficient distribution transformer and uhv transmission transformer, etc. The product performance and dimensional accuracy has reached the domestic leading level, the market share of non-oriented electrical steel in the home appliance industry is the first in the world, oriented electrical steel ranks the first in the world of transformer materials, and is growing into the "world's leading electrical steel manufacturer".



首钢电工钢发展历程 --Developing History of Shougang Electrical Steel

- 2005 首钢与钢铁研究总院成立电工钢联合研发平台
- 2008 冷轧电工钢项目动工
- 2010 第一条连续退火线热试投产，第一卷无取向电工钢下线
- 2011 酸连轧线投产，产品板形及厚度控制水平达到国际先进行列
- 2012 无取向高牌号生产流程全线贯通
- 2013 无取向电工钢在大电机、家电等行业实现全面推广应用
- 2014 无取向电工钢年产 115 万吨，达到设计产能
- 2015 无取向电工钢年产 118 万吨，无取向电工钢产量实现全球单体生产工厂第一
- 2016 新能源汽车驱动电机用无取向产品全系列覆盖
- 2017 无取向极薄规格 0.10/0.15mm 产品下线
- 2018 建成工信部首个冷轧智能工厂示范项目
- 2019 硅钢应用技术研究实验室建设完成并运行，通过 CNAS 认证
- 2020 建立欧洲、亚太技术服务办事处，技术服务范围覆盖全球

- 2005 The United R&D Center of Electrical Steels was established.
- 2008 The Project of Shougang Electrical Steel began to construct.
- 2010 the first continuous annealing line put into operation, and the first coil of NGO was produced.
- 2011 PL-TCM put into operation, the flatness and thickness of Shougang electric steel reached the international advanced level.
- 2012 HNGO production process through the whole line.
- 2013 NGO has been widely applied in large motor and home appliance
- 2014 NGO with an annual output of 1.15 million tons, reach design capacity.
- 2015 NGO with an annual output of 1.18 million tons, NGO production to achieve the world's first monomer production plant
- 2016 The whole series of NGO for new energy vehicle drive motors are fully covered
- 2017 Extremely thin size 0.10/0.15mm product of NGO output
- 2018 The demonstration project of the first intelligent cold rolling plant of the Ministry of Industry and Information Technology
- 2019 The construction of the silicon steel application technology research laboratory has been completed and put into operation, which has passed the CNAS accreditation
- 2020 Set up technical service offices in Europe and Asia Pacific, technical service scope covering the world

检测系统 - Testing System

电工钢全自动分析中心是国内冶金行业最先进的实验室之一，配备有自动直读光谱分析系统、自动 X 荧光分析系统、自动渣样检测分析系统；理化检测中心具有中国合格评定国家认可委员会颁发的 CNAS 国家实验室认可资质证书，成为具有对外承担独立检测能力的第三方认可实验室，检测范围包括金属与合金、矿石与矿物、燃料、水、金属与金属制品、铁磁材料等，检测数据具有行业权威性和法律效力。

理化检测中心配置检验设备 600 余台套，其中包含磁性测量仪、直读光谱仪、碳硫分析仪、定硫分析仪、定氢分析仪和氧氮分析仪、全自动冲击试验机、全自动拉伸试验机、低倍试验专用设备电解腐蚀机、落锤撕裂试验机、全自动电子万能材料试验机、金相光学显微镜、X 射线荧光光谱仪、等离子体发射光谱仪等先进检验设备。

首钢建立有应用技术实验室，具备家电、新能源、无人机及变压器测试仿真能力，全力打造从选材、加工到应用的全生命周期服务能力。拥有伺服中走丝线切割机、全自动激光切割机、电机定子铁心测试设备、AVL 新能源汽车电机测试系统等先进设备。

Electric Steel automatic analysis center is one of the most advanced laboratories in the domestic metallurgical industry, equipped with automatic direct reading spectrum analysis system, automatic X-ray fluorescence analysis system, automatic slag sample detection and analysis system; The Physical and Chemical Testing Center has CNAS National Laboratory Accreditation Certificate issued by The China National Accreditation Service for Qualification Assessment, and has become a third-party accredited laboratory with independent testing capabilities. The testing scope includes metals and alloys, ores and minerals, fuels, water, metals and metal products, ferromagnetic materials, etc. The test data has the authority of the industry and legal effect.

The physical and chemical testing center is equipped with more than 600 sets of testing equipment. Containing magnetic measuring instrument, direct reading spectrometer, carbon sulfur analyzer, oxygen and sulfur analyzer, hydrogen analyzer nitrogen analysis instrument, automatic impact testing machine, tensile testing machine, automatic low power test special equipment for electrolytic etching machine, drop weight tear test machine, automatic electronic universal material testing machine, metallographic optical microscope, X-ray fluorescence spectrometer, plasma emission spectrometer and other advanced testing equipment.

Shougang has established the application technology laboratory, has the home appliances, new energy, uav and transformer test and simulation capabilities, to create a full life cycle service capacity from material selection, processing to application. It has advanced equipment such as wire cutting machine, automatic laser cutting machine, motor stator core testing equipment, AVL new energy vehicle motor testing system and so on.

质量体系 -- Quality System

- ISO9001 质量管理体系
- IATF16949 汽车供应商质量管理体系
- ISO14001 环境管理体系
- ISO45001 职业健康安全管理体系
- ISO10012 测量管理体系
- ISO50001 能源管理体系
- SGS 国际环保认证
- 硅钢理化检验室通过 CNAS 认证

- ISO9001 Quality Management System
- IATF16949 Automotive Supplier Quality Management System
- ISO14001 Environmental Management System
- ISO45001 Occupational Health and Safety Management System
- ISO10012 Measurement Management System
- ISO50001 Energy Management System
- SGS International Environmental Certification
- CNAS Authentication

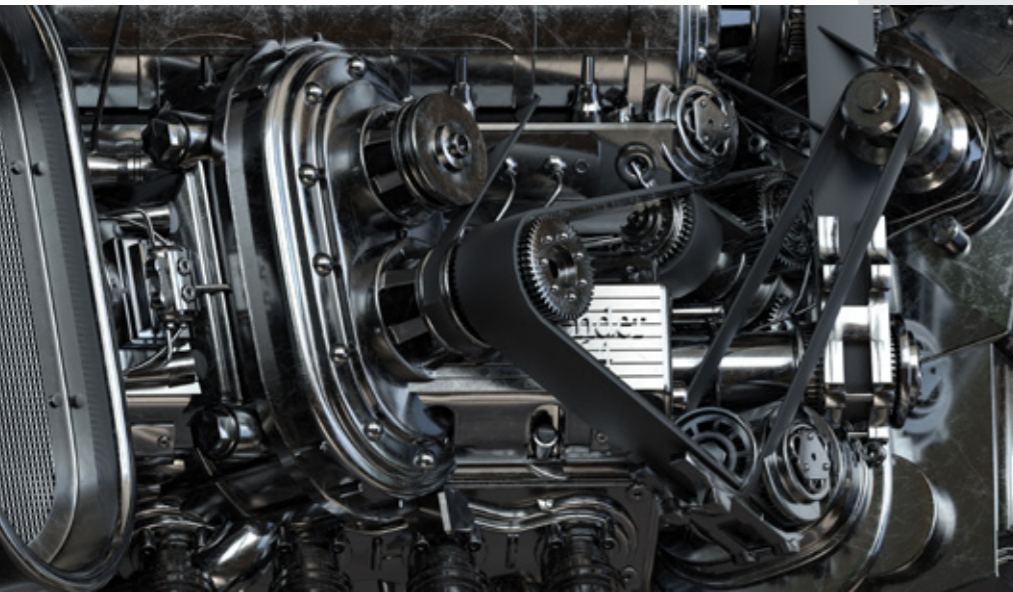

Chapter 2 Products for NGO

第二章 首钢无取向电工钢产品介绍

自从 2010 年 7 月份第一卷下线以来，经过近几年的产品研发和市场开拓，目前形成了通用产品、高效产品、去应力退火产品、新能源汽车用产品四大系列的无取向产品体系，产品质量稳步提升，广泛应用于家电和电机行业，得到广大客户的高度认可，形成了无取向电工钢全系列产品的生产能力。

Since July 2010 the first non oriented electrical steel was produced, it forms four series products include general products, high efficient products, stress relief annealing products, new energy vehicles of non oriented electrical steel product system through the product development and market development in recent years, and product quality steadily improve. These were widely used in home appliances and motor industry, and get highly recognized by customers. All grade products of non oriented electrical steel have formed now.

牌号表示方法 --Designation Method

首钢电工钢牌号由 5 部分组成，最大使用位数为 9 位。对于为个性化需求用户提供的电工钢牌号命名规则另行规定。



- ⑤最大为四位，表示以 W/kg 为单位，该公称厚度比总损耗保证值 P1.5/50(或 P1.0/400) 的 100 倍
- ④表示高磁感 G、高效 H 或特殊产品
- ③表示无取向电工钢产品
- ②首钢汉语拼音的首字母，表示首钢产品
- ①最大为三位，表示以 mm 为单位，材料公称厚度的 100 倍

Shougang electrical steel brand consists of 5 parts, the maximum number of bits used for the 9. For the individual needs of users of electrical steel brand naming rules shall be specified separately.

Notes:

- ① 100 times of nominal thickness (mm)
- ② Shougang
- ③ NGO electrical steel
- ④ High magnetic induction electrical steel
- ⑤ 100 times of core loss guaranteed value P1.5/50 (W/kg)

产品系列 --Product Series

产品的主要规格 Product main specifications

产品系列 Product series	主要规格 The main specifications
通用系列 General series	0.30mm、0.35mm、0.50mm、0.65mm
高效系列 High efficient series	0.35mm、0.50mm
去应力退火系列 Stress relief annealing series	0.35mm、0.50mm
新能源汽车用系列 New energy vehicle series	0.20mm、0.25mm、0.27mm、0.30mm

产品的适用行业 Product main features

产品系列 Product series	适用行业 Applicable industry
通用系列 General series	常规要求的电机企业 Motor Company general requirements
高效系列 High efficient series	高效电机、高效压缩机、变频电机等 High efficient motor, high efficient compressor motor, frequency conversion motor etc.
去应力退火系列 Stress relief annealing series	适合高速冲床加工产品、EI 变压器、空调电机等 high speed stamping products, EI transformer, air conditioner motor etc.
新能源汽车用系列 New energy vehicle series	汽车驱动电机、变压器、电抗器等 automobile motor, transformer, reactor etc

产品规格 --Product Specification

公称厚度 Nominal Thickness (mm)	公称宽度 Nominal Width (mm)	内径 Inner Diameter (mm)	外径 External Diameter (mm)	卷重 Coil Weight (t)
0.10-0.65	1000-1200	508	800-1600	3-9 15-21

尺寸公差 -- Dimensional Tolerances

公称厚度 Nominal Thickness (mm)	厚度允许偏差 Allowable thickness deviation (mm)	纵向厚差 Longitudinal thick deviation (mm)	横向厚差 Lateral thick deviation (mm)
	不大于 Be not more than		
≤ 0.35	±0.028	+0.018 0	+0.020 0
> 0.35 ~ 0.50	±0.035	+0.025 0	+0.020 0
> 0.50	±0.040	+0.035 0	+0.030 0

注：a. 焊缝处厚度增加值应不超过 0.10mm。

b. 任意 2000mm 长钢带或一张钢片上厚度偏差。

c. 仅适用于宽度大于 150mm 的钢带，对于窄带，需另签协议。

Attention:

a. The increase in thickness at the weld shall not exceed 0.10mm

b. Thickness deviation on any 2000mm long steel strip or a steel sheet

c. The thickness deviation of any 2000mm long steel strip or one steel sheet is only applicable to the steel strip whose width is greater than 150mm. For narrow strips, a separate agreement must be signed.

宽度公差 --Width Tolerances

公称宽度 Nominal Width (mm)	允许宽度偏差 Allowable Width deviation (mm)
≤ 150	+0.2 0
> 150~300	+0.3 0
> 300~600	+0.5 0
> 600~1000	+1.0 0
> 1000~1250	+1.5 0

注：经协议，可为负偏差。

Attention: By agreement, it can be negative deviation

电磁性能标准值 --Standard Value of Electromagnetic Property

通用系列 --General series

牌号 Grade	公称厚度 Nominal Thickness (mm)	理论密度 Theoretical density (kg/dm ³)	最大铁损 P15/50 Max.loss(W/kg)		最小磁感 Min.Magnetic induction(T)			
			50Hz	60Hz	B25	B50	B100	
30SW230	0.3	7.65	2.30	2.90	1.49	1.60	1.70	
35SW230	0.35	7.60	2.30	2.90	1.49	1.62	1.70	
35SW250		7.65	2.50	3.14	1.49	1.62	1.70	
35SW270		7.65	2.70	3.36	1.49	1.62	1.70	
35SW300		7.65	3.00	3.74	1.49	1.62	1.70	
35SW330		7.65	3.30	4.12	1.50	1.62	1.71	
35SW360		7.65	3.60	4.55	1.51	1.63	1.72	
35SW400		7.65	4.00	5.10	1.53	1.64	1.74	
35SW440		7.70	4.40	5.60	1.54	1.65	1.74	
50SW230		0.50	7.60	2.30	3.00	1.49	1.62	1.70
50SW250			7.60	2.50	3.21	1.49	1.62	1.70
50SW270	7.65		2.70	3.47	1.49	1.62	1.70	
50SW290	7.65		2.90	3.71	1.49	1.62	1.70	
50SW310	7.65		3.10	3.95	1.49	1.62	1.70	
50SW330	7.65		3.30	4.20	1.49	1.60	1.70	
50SW350	7.65		3.50	4.45	1.50	1.62	1.70	
50SW400	7.70		4.00	5.10	1.53	1.64	1.73	
50SW470	7.70		4.70	5.90	1.54	1.65	1.74	
50SW530	7.70		5.30	6.66	1.56	1.65	1.75	
50SW600	7.75		6.00	7.55	1.57	1.67	1.76	
50SW700	7.80		7.00	8.80	1.60	1.69	1.77	
50SW800	7.80		8.00	10.10	1.60	1.70	1.78	
50SW1000	7.85		10.00	12.60	1.62	1.73	1.81	
50SW1300	7.85		13.00	16.40	1.62	1.74	1.81	
65SW400	0.65		7.65	4.00	5.20	1.52	1.65	1.72
65SW600			7.75	6.00	7.71	1.56	1.68	1.76
65SW700			7.75	7.00	8.89	1.57	1.67	1.76
65SW800			7.80	8.00	10.26	1.60	1.70	1.78
65SW1000			7.80	10.00	12.77	1.61	1.71	1.80
65SW1300		7.85	13.00	16.60	1.61	1.71	1.80	

高效系列 --High Efficient Series

牌号 Grade	公称厚度 Nominal Thickness (mm)	理论密度 Nominal Density (kg/dm ³)	最大铁损 P15/50 Max. loss (W/kg)	最小磁感 B50 Min. Magnetic induction (T)
35SWH250	0.35	7.65	2.50	1.68
50SWH470	0.50	7.70	4.70	1.72
50SWG470	0.50	7.75	4.70	1.72
50SWH600	0.50	7.75	6.00	1.72
50SWH800	0.50	7.80	8.00	1.74
50SWH1300	0.50	7.85	13.0	1.76

去应力退火系列 --Stress Reliefannealing Series

牌号 Grade	公称厚度 Nominal Thickness (mm)	理论密度 Nominal Density (kg/dm ³)	最大铁损 P15/50 Max. loss (W/kg)	最小磁感 B50 Min. Magnetic induction (T)
35SWR300	0.35	7.80	3.00	1.73
50SWR350	0.50	7.80	3.50	1.74
50SWR450	0.50	7.85	4.50	1.72

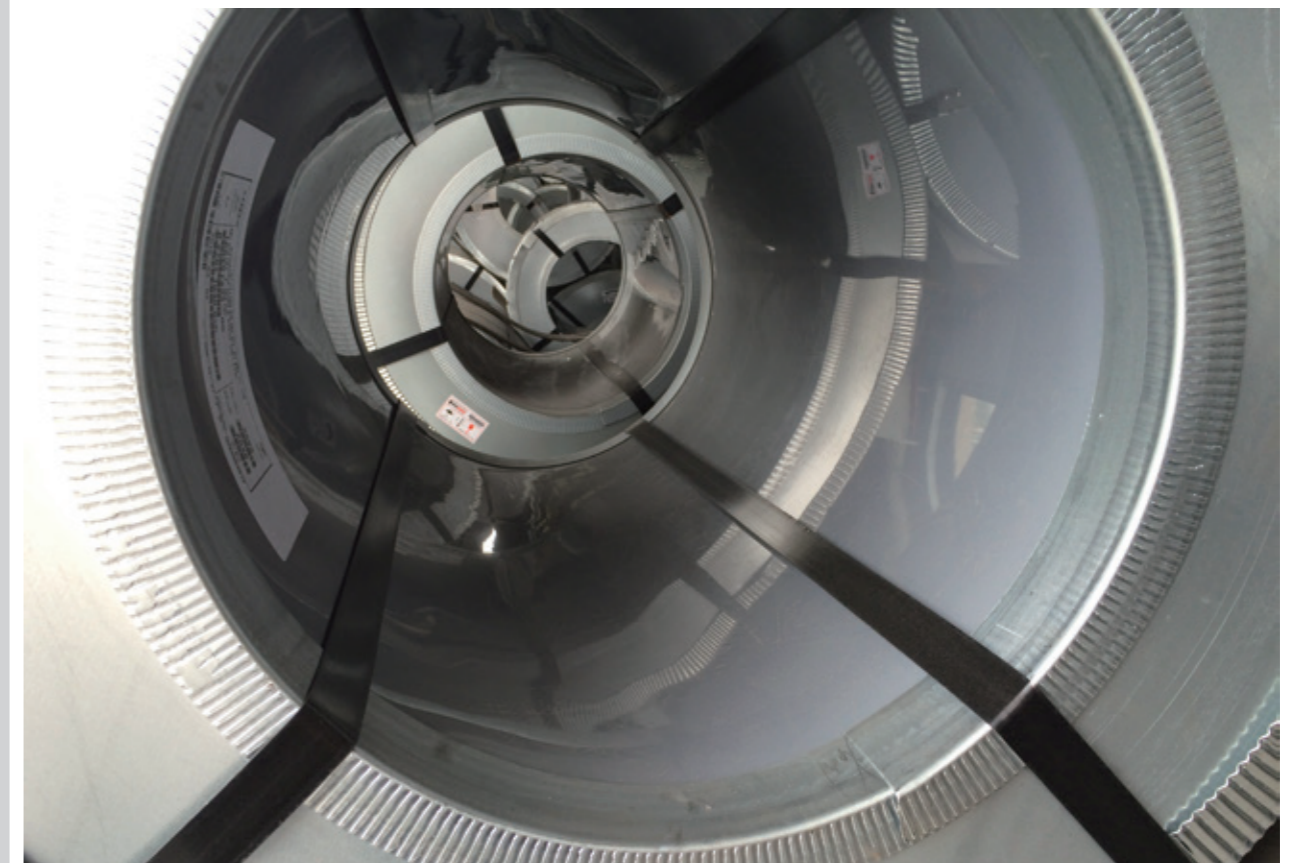

新能源汽车用系列 --New Energy Vehicle Series

牌号 Grade	公称厚度 Nominal Thickness (mm)	理论密度 Nominal Density (kg/dm ³)	最大铁损 P10/400 Max. core loss (W/kg)	最小磁感 B50 Min. Magnetic induction (T)
20SW1200	0.20	7.60	12.0	1.61
20SW1500	0.20	7.65	13.0	1.64
25SW1250	0.25	7.60	12.5	1.63
25SW1250H	0.25	7.60	12.5	1.65
25SW1300	0.25	7.60	13.0	1.63
27SW1400H	0.27	7.60	14.0	1.65
27SW1400	0.27	7.60	14.0	1.64
27SWH1400	0.27	7.65	14.0	1.64
27SWG1400	0.27	7.65	14.0	1.67
30SW1500	0.30	7.60	15.0	1.64
30SWH1500	0.30	7.65	15.0	1.65
30SWG1500	0.30	7.65	15.0	1.67
35SW1700	0.35	7.60	17.0	1.64
35SWG1700	0.35	7.65	17.0	1.68
35SW1700H	0.35	7.60	17.0	1.63
35SW1900	0.35	7.65	19.0	1.66
35SWH1900	0.35	7.65	19.0	1.67

注: a. 检测依据 GB/T3655-2008。
 b. 检测试样纵横向各半。
 c. 对于消除应力退火型无取向电工钢系列产品的磁性能测试仅适用于试样在 750℃下, 经 2 小时消除应力退火后的状态。
 d. P15/50 表示在最大磁感应强度为 1.5T, 频率为 50Hz 时, 单位 kg 试样的铁芯损耗。P10/400 表示在最大磁感应强度为 1.0T, 频率为 400Hz 时, 单位 kg 试样的铁芯损耗。
 e. B50 表示对应于磁场强度为 5000A/m 时的磁感应强度。

Attention:
 a. Measurement is made in accordance with GB/T3655-2000.
 b. The number of the transverse and vertical samples are the same.
 c. The magnetic properties of stress relief annealing products are only tested at 750 °C within 2 hours annealing .
 d. P15/50 is the core loss with 1.5T and 50Hz. P10/400 is the core loss with 1.0T and 400Hz.
 e. B50 is the magnetic induction with 5000A/m.

典型电磁性能 --Typical Magnetic Properties
通用系列 --General Series

牌号 Grade	公称厚度 Nominal Thickness (mm)	理论密度 Theoretical density (kg/dm ³)	铁损 Coreloss(W/kg)	磁感 Magnetic Induction (T)
			P15/50	B50
30SW230	0.30	7.65	2.20	1.66
35SW230	0.35	7.60	2.15	1.65
35SW250		7.65	2.25	1.67
35SW270		7.65	2.30	1.67
35SW300		7.65	2.55	1.68
35SW360	0.50	7.65	2.80	1.68
35SW440		7.70	2.90	1.69
35SW550		7.75	3.60	1.70
50SW250		7.60	2.35	1.65
50SW270		7.65	2.45	1.68
50SW290		7.65	2.55	1.68
50SW310	0.65	7.65	2.80	1.69
50SW350		7.65	2.90	1.69
50SW400		7.65	3.00	1.69
50SW470		7.70	3.60	1.69
50SW600		7.75	3.70	1.70
50SW700		7.80	4.40	1.72
50SW800		7.80	4.60	1.73
50SW1000		7.85	5.30	1.75
50SW1300		7.85	5.60	1.75
65SW400		0.65	7.65	3.80
65SW600	7.75		4.55	1.70
65SW800	7.80		5.60	1.72
65SW1000	7.85		6.00	1.74

高效系列 --High Efficient Series

牌号 Grade	公称厚度 Nominal Thickness (mm)	理论密度 Nominal Density (kg/dm ³)	铁损 Coreloss(W/kg)	磁感 Magnetic Induction (T)
			P15/50	B50
35SWH250	0.35	7.65	2.40	1.69
50SWH470	0.50	7.70	3.05	1.72
50SWG470	0.50	7.75	3.25	1.73
50SWH600	0.50	7.75	3.60	1.74
50SWH800	0.50	7.80	4.50	1.76
50SWH1300	0.50	7.85	5.6	1.78

去应力退火系列 --Stress Relief Annealing Series

牌号 Grade	公称厚度 Nominal Thickness (mm)	理论密度 Nominal Density (kg/dm ³)	铁损 Coreloss(W/kg)	磁感 Magnetic Inductio (T)
			P15/50	B50
35SWR300	0.35	7.80	2.80	1.75
50SWR350	0.50	7.80	3.20	1.76
50SWR450	0.50	7.85	4.20	1.74



新能源汽车用系列 New energy vehicle series

牌号 Grade	公称厚度 Nominal Thickness (mm)	理论密度 Theoretical density (kg/dm ³)	铁损 Coreloss(W/kg)	磁感 Magnetic Induction (T)
			P10/400	B50
20SW1200	0.20	7.60	11.0	1.63
20SW1500	0.20	7.65	12.0	1.66
25SW1250	0.25	7.60	12.0	1.66
25SW1250H	0.25	7.60	11.6	1.67
25SW1300	0.25	7.60	12.2	1.65
27SW1400H	0.27	7.60	12.4	1.67
27SW1400	0.27	7.60	12.7	1.66
27SWH1400	0.27	7.65	13.3	1.66
27SWG1400	0.27	7.65	12.8	1.69
30SW1500	0.30	7.60	13.6	1.66
30SWH1500	0.30	7.65	14.3	1.67
30SWG1500	0.30	7.65	13.8	1.69
35SW1700	0.35	7.60	15.8	1.66
35SWG1700	0.35	7.65	15.8	1.70
35SW1700H	0.35	7.60	15.5	1.65
35SW1900	0.35	7.65	16.5	1.68
35SWH1900	0.35	7.65	17.5	1.69

注: a. 检测依据 GB/T3655-2008。
b. 检测试样纵横各半。
c. 对于消除应力退火型无取向电工钢系列产品的磁性能测试仅适用于试样在 750℃下, 经 2 小时消除应力退火后的状态。
d. P15/50 表示在最大磁感应强度为 1.5T, 频率为 50Hz 时, 单位 kg 试样的铁芯损耗。P10/400 表示在最大磁感应强度为 1.0T, 频率为 400Hz 时, 单位 kg 试样的铁芯损耗。
e. B50 表示对应于磁场强度为 5000A/m 时的磁感应强度。

Attention:
a. Measurement is made in accordance with GB/T3655-2000.
b. The number of the transverse and vertical samples are the same.
c. The magnetic properties of stress relief annealing products are only tested at 750 °C through 2 hours annealing .
d. P15/50 is the core loss with 1.5T and 50Hz. P10/400 is the core loss with 1.0T and 400Hz.
e. B50 is the magnetic induction with 5000A/m.

典型机械性能 --Typical Mechanical Properties

产品机械性能 Product Mechanical Properties

牌号 Grade	公称厚度 Nominal Thickness (mm)	理论密度 Theoretical density (kg/dm ³)	屈服强度 Yield strength (N/mm ²)	抗拉强度 Tensile strength (N/mm ²)	硬度 HV1 Hardness	延伸率 Elongation (%)
35SW230	0.35	7.60	430	530	214	8
35SW250		7.65	410	515	200	15
35SW300		7.65	370	500	185	25
35SW360		7.65	325	470	165	30
35SW440		7.70	280	425	150	30
35SW550		7.75	260	422	142	37
50SW250	0.5	7.60	430	530	220	15
50SW270		7.65	410	515	200	15
50SW290		7.65	410	515	200	15
50SW310		7.65	375	510	185	30
50SW350		7.65	370	510	185	35
50SW400		7.65	320	460	165	35
50SW470		7.70	260	420	140	40
50SW600		7.75	240	400	126	40
50SW700		7.80	220	379	113	37
50SW800		7.80	230	379	113	37
50SW1000		7.85	240	370	110	46
50SW1300		7.85	240	370	109	48

绝缘涂层 --Insulation Coating

涂层种类 Coating Types

涂层种类 Coating type	组分类别 Composing Component	涂层厚度 (μm) Coating thickness range	附着性 Adhesion	耐热性 Heat resistance	耐腐蚀性 Corrosion resistance	冲片性 stamping ability	叠片系数 lamination factor	焊接性 weldability
M4	半有机 Semi-organic	0.4-1.2	很好 well	在非氧化环境下， 可耐 800°C 去应力退火 In non-oxidation environment the coating is normal through 800°C stress relieving annealing.	很好 well	很好 well	高 high	很好 well
M1	环保涂层 Environmental protection coating	0.4-1.2	很好 well	在非氧化环境下， 可耐 800°C 去应力退火 In non-oxidation environment the coating is normal through 800°C stress relieving annealing.	很好 well	好 well	高 high	很好 Well
M5	环保厚涂层 Thick environmental protection coating	2.0-5.0	很好 well	在非氧化环境下， 可耐 800°C 去应力退火 In non-oxidation environment the coating is normal through 800°C stress relieving annealing.	很好 well	好 well	高 high	很好 Well

注：如用户对涂层无特殊要求，默认选择 M4 涂层。
Attention: if users have no special requirements, M4 is the default coating. 有害物质限定承诺 Hazardous substances limited commitment
首钢电工钢产品符合 Rohs、REACH 等有害物质限定要求。
Shougang electrical steel products meet the limited requirement of Rohs, REACH and other harmful substances.

去应力退火 --Stress Relief Annealing

对于首钢全工艺电工钢产品，通常不要求退火，但由于钢板在剪切、冲压工程中总会产生应力，从而恶化电工钢磁性，如铁损、导磁率等，因此，通常通过消除应力退火来恢复由金属加工等造成的磁性恶化。

此外，通过去应力退火还可以使电工钢晶粒继续长大，有进一步降低电工钢铁损的作用。

Usually, it is unnecessary to anneal for the electric steel products. However, by stress relief annealing, the stress, caused by shearing and punching the steel plate which will deteriorate the magnetic properties such as causing higher core loss and worse magnetic permeability, will be eliminated, and magnetic properties will be cured or even improved.

Moreover, through stress relief annealing, core loss is lower by grain growth.

注意事项 Attention

退火时间 --Annealing Time

有效退火温度范围 650℃ -820℃，升温速度以 6.5℃ /s 较为合适。退火温度应低于 800℃，高于此温度可能导致涂层的破坏。

退火气氛 --Annealing atmosphere

渗氮及氧化气氛必须避免，因为这会导致钢板磁性的恶化，因此，必须合理控制退火气氛，要求低的露点（DP<0℃）以保证在退火过程中，不降低绝缘性能。

Effective annealing temperature should be controlled within from 650 °C to 820 °C, and appropriate heating rate is 6.5 °C /s. Annealing temperature should keep below 800 °C, or coating may be damaged.

Nitriding and oxidizing atmosphere which lead magnetic deterioration of plate must be avoided. Therefore, it is reasonable to control annealing atmosphere, requiring low dew point (DP<0°C) to ensure insulation during annealing.

其它 Others

为防止粘片，冲片不能堆垛太高。

必须消除冲压或者剪切过程中残留的冲压油。

In order to prevent sticking, stamping sheets cannot stack too high.

The residual stamping oil generated by stamping or cutting must be clear.

Chapter 3 Application

第三章 首钢无取向电工钢产品应用

应用领域 --Application Field

首钢电工钢在广大客户的支持下，产品研发及产品质量取得很大的突破，客户群体不断扩大，从最初的几家客户试用，到目前为时的 300 多家客户使用，市场占有率逐步提高，首钢电工钢品牌已经树立。建立有应用技术实验室，具备家电、新能源、无人机及变压器测试仿真能力，全力打造从选材、加工到应用的全生命周期服务能力。

Shougang Electric steel in the support of the majority of customers, product research and development and product quality has made a great breakthrough, the customer group continues to expand, from the initial few customers trial, so far more than 300 customers use, the market share gradually increased, shougang electric steel brand has been set up. It has established the application technology laboratory, and has the testing and simulation capability of home appliances, new energy, uav and transformer, and makes full efforts to build the full life cycle service capability from material selection, processing to application.



产品特点 --Product Characteristic

首钢无取向产品进入市场以来，以优良的产品磁性能和出色的加工性能赢得了众多客户的青睐，产品特点主要体现在以下几个方面：

低铁损高磁感

电机能耗主要包括电工钢铁芯的铁损和绕组的铜耗。电工钢片铁损的降低、磁感的提高一方面可降低能耗，另一方面可提高设计磁密使电机励磁电流降低，从而降低铜耗并省铜。因此，电工钢片铁损的降低、磁感的提高能够达到高效并降低用户生产成本的目的。首钢迁钢产品以优良的铁损水平得到了用户的广泛认可。

出色的加工性能

电工钢出色的加工性能可以提升产品冲片性，提高冲模寿命，保证冲片尺寸精确以及减小冲切毛刺，最终保证成品电机的性能。首钢迁钢产品根据用户的不同使用需求设计了满足不同模具要求的差异化产品。

高的尺寸精度

充分发挥新上设备和先进控制系统的后发优势，主要产品实物质量尺寸精度已经达到或超过了国内先进企业水平。减少用户生产过程的切片数，保证了电机铁芯叠装后的高度差，提高了生产效率和产品效率。

优良的表面绝缘性能

涂层的种类、工艺和质量将对电工钢片间相互绝缘性、冲片性、焊接性及耐油性等产生重大影响，从而进一步影响电工钢本身的铁损水平乃至产品的性能。迁钢产品的涂层特性主要是涂层均匀性好，耐高温，附着性和绝缘性能优。

Product Characteristic

Since non oriented products launched, because of excellent magnetic properties and machinability, Shougang have win the favor of many customers, product characteristics are mainly embodied in the following aspects.

Low core loss and high magnetic induction

The energy consumption of the motor includes electrical steel core loss and winding copper loss. If the electrical steel sheet iron loss reduce, and magnetic induction improve, energy consumption reduce, on, and the design for reducing the magnetic emissary motor excitation current improve for reducing the consumption of copper. Therefore, low core loss and high magnetic induction can improve the efficiency and reduce the production cost for the user. Shougang products with good iron levels have been widely recognized by users.

Excellent machinability

Excellent machinability of electrical steel can enhance product stamping, increase the service life of the equipment, ensure the accurate size d decrease the punching blanking burr, and ultimately ensure the properties of finished motor. According to different requirements of the user' s, Shougang design to meet the different requirements of differentiated products.

High dimensional accuracy

Giving full play to the new equipment and advanced control system to the advantage, the main product quality and size precision have reached or exceeded the domestic advanced level of enterprises. Those has reduced the number of user slice production process, ensured the motor core lamination of the height difference, improve d the production and product efficiency.

Good insulation surface

The variety, process and quality of coating will influence electrical steel' s insulation, punching, welding and oil resistance, thus further influence electrical steel core loss and product properties. The coating has uniformity, high temperature resistance, adhesion and insulation performance.

应用案例 -- Application Case

电磁性能是电工钢材料最重要的性能指标之一，优良的电磁性能是制造高效率电机产品的保证。用户使用实绩告诉我们首钢无取向电工钢在同行业中一直处于较为领先的水平。

Magnetic properties of electrical steel material is one of the most important performance index, and excellent electromagnetic performance makes high-efficiency motor product guarantee. Users said that the performance of non oriented electrical steel had been in the leading level in the same industry.

某高效冰箱制冷压缩机电机产品 COP 值情况 (50WH600)

A high-efficient refrigerator compressor motor product COP value (50SWH600)

厂家 Factory	电压 (V) Voltage (V)	频率 (HZ) Frequency (HZ)	制冷量 (W) Refrigerating capacity (W)	COP
对标钢厂 1 steel mill 1	220-240	50	171.3	1.810
对标钢厂 2 Steel mill 2	220-240	50	171.5	1.813
对标钢厂 3 Steel mill 3	220-240	50	172.5	1.816
首钢 50SWH600 Shougang 50SWH600	220-240	50	174.1	1.828

某空调电机产品电机效率情况 (30W230)

An air conditioner motors motor efficiency (30W230)

厂家 Factory	电机效率 Motor efficiency
对标钢厂 Steel mill	94.00%
首钢 30W230 ShouGang 30W230	95.20%



用户服务 --Customer service

为用户提供优质快捷的服务是首钢电工钢一贯的宗旨，我们的技术人员通过贴心服务了解用户的产品需求，开发更有竞争力的产品；我们的客户代表致力于为客户提供高效、便捷的售前、售中及售后服务。

High quality and convenient service for users are always the purpose of Shougang electrical steel. Through intimately service, our technical personnel understand the customer's demand, and develop more competitive products; Our customer representatives are committed to provide customers with efficient, convenient pre-sale, sale and after sale service.

1、产品策划 Product planning

为了更好的满足用户的需求，在售前，充分调研用户的产品使用需求，根据用户的要求设计满足用户需要的产品。

In order to better meet the needs of users, Shougang steelfully meets user's product demands with full investigation before the pre-sale, according to the requirements of the user design production to meet the needs of users.

2、精益制造 Lean manufacturing

推进一贯制质量管理，即将一贯制质量管理的标准化、量化、程序化、信息化先进经验推广到服务工作的每一个环节，提升精准化管理水平，形成多层次有机协同的持续改进体系；快速对需求响应、可靠的交货保证、全程合同与物流跟踪、高效的运输通道、建立起以“全面相应、管理统一、分类细化、快捷高效、持续改进”为主要特征的产品投诉和异议处理制度。

To promote consistent system of quality management, expand of every aspect of standardization, quantification, program, information advanced experience of consistent system, the precision management level enhances, and a multi-level organic synergy of continuous improvement system forms; Shougang has have fast demand response, reliable delivery guarantee, the contract and logistics tracking, efficient transport channel, and set up a "comprehensive response, unified management, classification, efficient, continuous improvement" as the main characteristics of the product complaint and objection handling system.

3、个性化服务 Personalized service

为不同细分客户制定个性化营销模式，根据客户需求，为客户量身定做服务产品，例如打破业务流程中的信息沟通壁垒，提高快速响应能力，缩短业务各环节的处理周期，降低管理成本。同时与各行业龙头客户建立更为紧密的战略合作伙伴关系，集中首钢优势力量和资源，满足大客户临时需求，此外还为客户提供专业定制化的配套材料以及个性化的物流服务。

According to customers' demands, Shougang makes the personalized marketing modes, such as a breakup in the business process of information communication barriers, the rapid response capability, the short processing cycle of each section of the business, and the low cost of management. At the same time, Shougang establishes more close strategic partnership with the leading customers, uses the advantage of centralized power and resources to meet the customers' temporary demands. Shougang also provides materials and professional customized for customers.

设计仿真 -- Design and Simulation

电磁仿真 | Electromagnetic Simulation

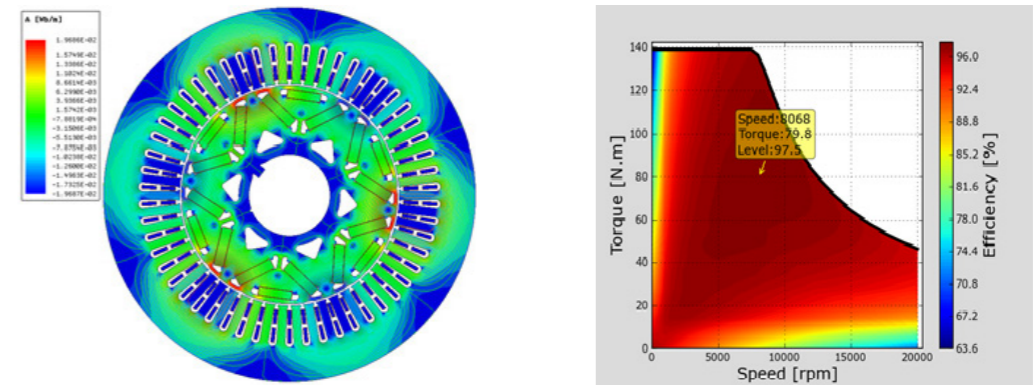

加工制造 -- Manufacture

定转子加工制造 | Manufacture of Stator and Rotor



制造技术研究 | Manufacture Technology Research

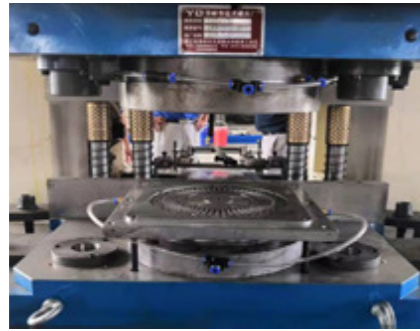

冲片 | Stamping



叠铆 | Interlock

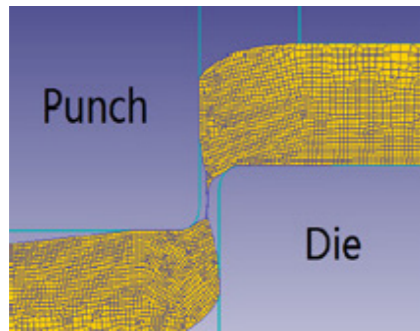

Punch

Die

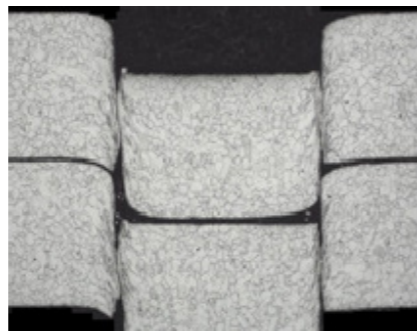

电机测试 --Motor Test

测试台架 | Test Bench



Chapter 4 Order and Service

第四章 订货及服务

首钢无取向电工钢产品标签 Product label

首钢集团 SHOUGANG GROUP			
品牌 BRAND	首钢	品名 PRODUCT	
牌号 STEEL GRADE		毛重(t) GROSS WEIGHT	净重(t) NET WEIGHT
标准 SPECIFICATION		卷重/捆包号 COIL/PACK No.	炉号 HEAT No.
规格(mm) SIZE		涂层种类 COATING TYPE	生产日期 DATE
合同号 CONTRACT No.		客户名称 PURCHASER	
新站号 DESTINATION		其它 OTHER	
制造厂: 首钢智新迁安电磁材料有限公司 MANUFACTURER: Shougang Zhixin Qian'an Electromagnetic Material Co.,LTD.			
MADE IN CHINA			

首钢无取向电工钢产品质保书 product warranty

		“首钢”牌产品质量证明书 QUALITY CERTIFICATE OF "SHOUGANG" BRAND		首钢集团地址: 中国北京市石景山区 ADD. OF SHOUGANG GROUP: SHIJINGSHAN DISTRICT, BEIJING, CHINA 邮政编码 POST CODE: 100043 电话 TEL.: 010-87092888 制造厂地址: 中国河北省迁安市 ADD. OF MANUFACTURER: Qian'an City Hebei Prov., China							
订货单位 Customer	合同号 Contract No.	车号 Train/Ship No.	收货单位 Purchaser	交货状态 Condition of Supply	证书编号 Certificate No.						
产品名称 Product	交货日期 Date of Delivery	记录号 Record No.	06-15-08-01-A								
规格 Specification	牌号 Steel Grade	页号 Page No.	第1页, 共1页								
序号 No.	地址号 No.	炉号 Heat No.	卷号/捆包号 Coil/Pack No.	厚度 Thick	宽度 Widt	长度 Lengt	油层 Oils	重量 Wt.	重量公差 Wt. Tol	屈服强度 Yield	抗拉强度 Tensile
1											
备注 Remarks:		1. 本产品经检验符合交付标准。 We hereby certify that material described here in has been tested with satisfactory results in accordance with the requirements of the above material specification. 2. 本质量证明书内容不作为交货条件。 Blank project the quality certificate are not as delivery conditions. 3. 盖章有效。 Sealed after the entry into force 4. 联系方式: TEL.: 0215-7706099 E-Mail: gms@sgcc.com 日期 Date: 2013-03-26								审核 Check	质量检验员 Person in Charge of Quality Inspection
订单号 Order No.											

产品包装 Product Packing

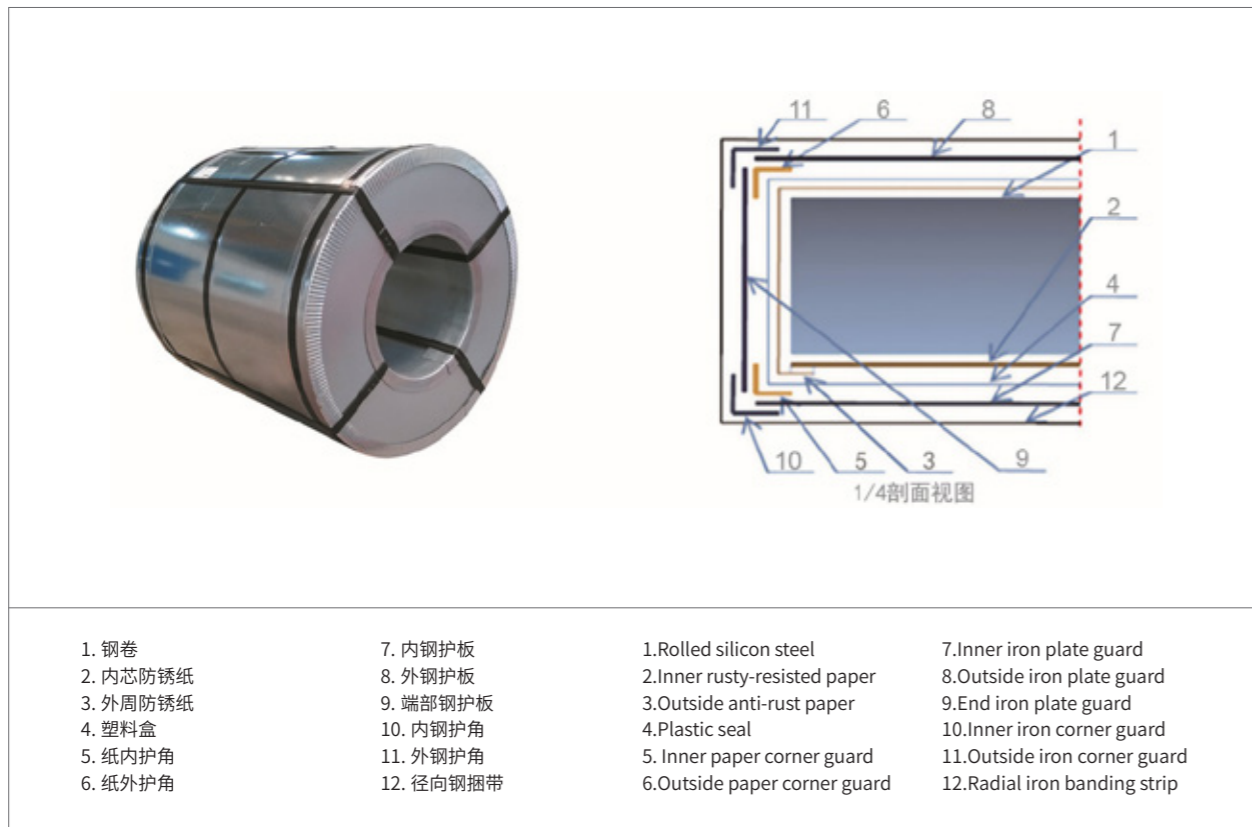

- | | | | |
|----------|-----------|-------------------------------|-------------------------------|
| 1. 钢卷 | 7. 内钢护板 | 1. Rolled silicon steel | 7. Inner iron plate guard |
| 2. 内芯防锈纸 | 8. 外钢护板 | 2. Inner rusty-resisted paper | 8. Outside iron plate guard |
| 3. 外周防锈纸 | 9. 端部钢护板 | 3. Outside anti-rust paper | 9. End iron plate guard |
| 4. 塑料盒 | 10. 内钢护角 | 4. Plastic seal | 10. Inner iron corner guard |
| 5. 纸内护角 | 11. 外钢护角 | 5. Inner paper corner guard | 11. Outside iron corner guard |
| 6. 纸外护角 | 12. 径向钢捆带 | 6. Outside paper corner guard | 12. Radial iron banding strip |

拆包注意事项 Notice of unpacking

冬季由于南北方温度、湿度差异较大，建议库存 36 小时后拆包，防止结露生锈。

Due to the difference of temperature and humidity in the South and North in winter, it is recommended to open the package after 36 hours to prevent condensation and rust.

通常的包装、运输、装卸和储存条件下，自制造完成之日起 12 个月内使用，以防止表面锈蚀。

无取向电工钢牌号比照 Grade comparison of different enterprises

产品牌号比照 --Product grade standard

类型 Type	公称厚度 (mm) Thickness	首钢 Shougang	新日铁 NSC	JFE	蒂森克虏伯 TKS	浦项 Posco	新利佩茨克 NI&Sco	阿姆可 AK
通用系列 General series	0.35	35SW230	35H230	35JN230	M235-35A	35PN230		
		35SW250	35H250	35JN250	M250-35A	35PN250	2413	M-15
		35SW270	35H270	35JN270	M270-35A	35PN270	2412	M-19
		35SW300	35H300	35JN300	M300-35A	35PN300	2411	M-22/M-27
		35SW360	35H360	35JN360		35PN360		
		35SW440	35H440	35JN440		35PN455		
		35SW550				35PN560		
	0.50	50SW230	50H230	50JN230	M230-50A	50PN230		
		50SW250	50H250	50JN250	M250-50A	50PN250		
		50SW270	50H270	50JN270	M270-50A	50PN270	2414	
		50SW290	50H290	50JN290	M290-50A	50PN290	2413	M-15
		50SW310	50H310	50JN310	M310-50A	50PN310	2412	M-19
		50SW350	50H350	50JN350	M350-50A	50PN350		M-22
		50SW400			M400-65A	50PN400		M-27/M-36
		50SW470	50H470	50JN470	M470-50A	50PN445	2214	
		50SW600	50H600	50JN600	M600-50A	50PN595	2212	
		50SW700	50H700	50JN700	M700-50A	50PN760		M-47
		50SW800	50H800	50JN800	M800-50A	50PN890	2011	
		50SW1000	50H1000	50JN1000	M940-50A	50PN1015		
		50SW1300	50H1300	50JN1300	M1100-50A	50PN1270		
	0.65	65SW400				65PN400		
		65SW800			65JN800	M800-65A	65PN890	M-47
		65SW1000			65JN1000	M1000-65A	65PN1015	
		65SW1300			65JN1300	M1300-65A	65PN1270	
	高效系列 High efficient series	0.35	35SWH250					
			35SWH300					
		0.50	50SWH470		50JNE470			
			50SWH600					
50SWH800								
50SWH1300								
去应力退火系 Stress relief annealing series	0.50	50SWR350		50JNA350				
		50SWR1300						

单位换算表 --Conversion table

项目名称 Item		单位 Unit		符号 Sign
长度	Length	米	(Meter)	m
质量	Mass	千克	(Kilogram)	kg
时间	Time	秒	(Second)	s
电流	Electric current	安培	(Ampere)	A
密度	Density	千克 / 立方米	(Kilogram Per Steres)	kg/m ³
电压	Voltage	伏特	(Volt)	V
电阻	Electric resistance	欧姆	(Ohm)	Ω
磁通	Magnetic flux	韦伯	(Weber)	Wb
磁通密度	Magnetic flux density	特斯拉	(Tesla)	T
磁场强度	Magnetic flux strength	奥斯特	(Oersted)	Oe
铁损	Core loss	瓦特 / 公斤	(Watt per Kilogram)	W/kg
频率	Frequency	赫兹	(Hertz)	Hz
功率	Power	瓦特	(Watt)	W
电感	Inductance	亨利	(Henry)	H

单位 Unit	初值 Multiply	倍数 by	结果 to obtain		
磁场强度 Magnetizing force	奥斯特	Oersted (Oe)	7.985×10	安培 / 米	Ampere per meter(A/m)
	奥斯特	Oersted (Oe)	2.021	安培 / 英寸	Ampere per inch(A/in)
	安培 / 米	Ampere per meter(A/m)	1.257×10 ⁻²	奥斯特	Oersted (Oe)
	安培 / 米	Ampere per meter(A/m)	2.540×10 ⁻²	安培 / 英寸	Ampere per inch(A/in)
	安培 / 英寸	Ampere per inch(A/in)	4.947×10 ⁻¹	奥斯特	Oersted (Oe)
	安培 / 英寸	Ampere per inch(A/in)	3.937×10	安培 / 米	Ampere per meter(A/m)
	安培 / 厘米	Ampere per centimeter(A/cm)	10 ²	安培 / 米	Ampere per meter(A/m)
磁感 Magnetic Induction	特斯拉	Tesla(T)	10 ⁴	高斯	Gauss(Gs)
	特斯拉	Tesla(T)	1	韦伯 / 平方米	Weber per square meter(Wb/m ²)
	高斯	Gauss(Gs)	10 ⁻⁴	韦伯 / 平方米	Weber per square meter(Wb/m ²)
	高斯	Gauss(Gs)	6.452	磁通量 / 平方英寸	Lines per square inch(Line/in ²)
	韦伯 / 平方米	Weber per square meter(Wb/m ²)	10 ⁴	高斯	Gauss(Gs)
	韦伯 / 平方米	Weber per square meter(Wb/m ²)	1	特斯拉	Tesla(T)
	韦伯 / 平方米	Weber per square meter(Wb/m ²)	6.452×10 ⁴	磁通量 / 平方英寸	Lines per square inch(Line/in ²)
	磁通量 / 平方英寸	Lines per square inch(Line/in ²)	1.550×10 ⁻¹	高斯	Gauss(Gs)
铁损 Core loss	瓦特 / 千克	Watt per kilogram(W/kg)	4.536×10 ⁻¹	瓦特 / 磅	Watt per pound(W/lb)
	瓦特 / 磅	Watt per pound(W/lb)	2.204	瓦特 / 千克	Watt per kilogram(W/kg)
长度 Length	米	Meter(m)	3.937×10	英寸	Inch(in)
	英寸	Inch(in)	2.540×10 ⁻²	米	Meter(m)
	米	Meter(m)	3.281	英尺	Feet(ft)
	英尺	Inch(in)	3.048×10 ⁻¹	米	Meter(m)
重量 Weight	千克	Kilogram(kg)	2.204	磅	Pound(lb)
	磅	Pound(lb)	4.536×10 ⁻¹	千克	Kilogram(kg)

产品销售合同 --Sales Contract

首钢智新迁安电磁材料有限公司钢铁产品销售合同

订单编号:

订单有效期:

本合同为卖方向买方销售钢铁产品所订立的销售合同,在友好、平等协商的基础上双方同意订立

以下条款:

- 一、合同标的、数量、价款、技术标准、运输条件等见附件。
- 二、合同标的价格为卖方挂牌价并扣减了本张订单订货数量对应的批量折扣。
- 三、合同履行地:卖方所在地。
- 四、交货验收:买方(或其提货人)在收到卖方交付的钢材产品及其他产品后,以卖方提供的交货清单为数量验收依据,如验收数量与交货数量误差超过千分之三,买方应保持货物原状,并在十日内向卖方提出书面异议。经双方协商一致解决。
- 五、合同变更:买卖双方协商一致方可变更本合同。
- 六、合同注明的到站未经卖方同意不得变更。买方擅自变更货物销售地区而导致原约定价格与卖方在该地区销售价格政策有差异的,卖方有权按实际销售地区价格结算。
- 七、合同生效条件:买卖双方签字并盖合同专用章。采用电子签章合同与手写签名、盖章的纸质合同具有同等的法律效力。

- 八、本合同未经双方同意不得转让。
- 九、本合同未作明确约定的,按《合同法》规定履行。
- 十、双方如果对本合同项下发生的异议,采取向卖方所在地人民法院提起诉讼。
- 十一、本合同预计资金占用额 元,总数量 吨。

十二、收货人(或提货人):

十三、运输方式:

到站卸点:

联系人:

电话:

专用线:

二到站:

预计运输价格:

运费结算方式:

卖方:首钢智新迁安电磁材料有限公司
地址:河北省唐山市迁安市西部工业区北安街025号

邮编:064404

电话:0315-7703732

传真:

税号:91130283MA09WM6M8X

现汇开户银行:中国建设银行股份有限公司迁安首钢支行

账号:13050162803709888888

电子银承开户银行:首钢集团财务有限公司 账号:20120121031001

法人代表或委托人(签字盖章):

买方:

地址: |

邮编:

电话:

传真:

税号:

开户银行:

账号:

法人代表或委托人(签字盖章)

备注:

合同签订时间:

合同签订地点:河北省唐山市迁安市

首钢智慧供应链平台 Shougang Intelligent Supply Chain Platform



首钢全球销售网络图 Shougang global sales network chart

首钢全球销售网络图
SHOUGANG GLOBAL SALES NETWORK CHART



CONTACT INFORMATION

Cao Liming

CORE STEEL CO.,LTD.

MOB: +86-158-0099-2824

E-Mail: youying@coresteel.co.jp

TEL: +81-6-6786-8302 FAX: + 81-6-6786-8305

ADD: FUKAKIKAWARAMACHI Bldg. 5F, 3-4-9, Kawaramachi, Chuo-ku, Osaka 541-0048, Japan
Room2601, Building-5, Royal Fortune Phase 2, Qingsheng Avenue, Fuqing, Fujian, China

Ilker Gundogdu

Wise Global Trade Corp.

101 Merritt 7 Corporate Park 3rd Floor Suite 50

Norwalk CT 06851 U.S.A.

ilker@wiseglb.com

+ 90 532 221 3745

北京首钢股份有限公司
Beijing Shougang Co.,Ltd

SGGF 978-7-203-1184-1



9 787203 118411